

#81692 - Shock Shaft Guards for Traxxas GTR Shocks

What's Included: 2 - Left Guards, 2 - Right Guards, 2 - Left Spring Cups, 2 - Right Spring Cups & 4 - M2.5 x 20mm S.H.C.S.

Before You Begin: *RPM* recommends removing the shocks from your vehicle to install your new *RPM* Shock Shaft Guards. Remove the stock M2.5 x 10mm S.H.C.S. securing the stock Traxxas spring cups to the shock rod ends (these screws will be reused - do not discard). Relieve the pressure of the springs on the spring cups to remove the spring cups from the shock shafts.

Assembly: 1) Compress the shock spring, then slip the **RPM Spring Cup** over the shock shaft and rod end. Align the hole on the slotted side of the Spring Cup for the M2.5 x 20mm S.H.C.S. with the screw hole in the rod end. Do not install the screw at this time.

2) Align the the **Guard** to the **Cup** as shown.

3) Using the included screws, bolt the **Guard** to the **Spring Cup** as shown in the illustration, making sure the M2.5 x 20mm screw goes through the slotted side of the **Spring Cup**. Use the stock M2.5 x 10mm screw removed earlier to finish securing the **Guard** to the **Spring Cup**.

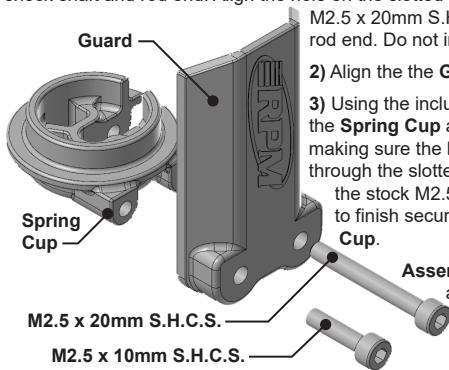

Assembly Notes: We mention "Left" and "Right" sides above, but our Guards will fit on either side of the vehicle. For us, the logo orientation determines side.